



Operating Manual
ALTAIR Single Gas
Gas Detection Wearable



Order No.: 10074380/04

Print Spec: 10000005389 (EO)

CR: 800000057743

⚠ WARNING!

Read this manual carefully before using or maintaining the device. The device will perform as designed only if it is used and maintained in accordance with the manufacturer's instructions. Otherwise, it could fail to perform as designed, and persons who rely on this device could sustain serious injury or death.

The warranties made by MSA with respect to the product are voided if the product is not installed and used in accordance with the instructions in this manual. Please protect yourself and your employees by following the instructions.

Please read and observe the WARNINGS and CAUTIONS inside. For additional information relative to use or repair, call 1-800-MSA-2222 during regular working hours.

For countries of Russian Federation, Republic of Kazakhstan and Republic of Belarus, the gas detector will be delivered with a passport document that includes valid approval information. On the CD with manual instruction attached to the gas detector the user will find the documents "Type Description" and "Test Method" - appendixes to Pattern Approval Certificate of Measuring instrument, valid in the countries of use.

MSA is a registered trademark of MSA Technology, LLC in the US, Europe and other Countries. For all other trademarks visit <https://us.msasafety.com/Trademarks>.

This device complies with part 15 of the FCC Rules. Operation is subject to the following two conditions: (1) This device may not cause harmful interference, and (2) this device must accept any interference received, including interference that may cause undesired operation.

You are cautioned that changes or modifications not expressly approved by the party responsible for compliance could void the user's authority to operate the equipment.

English:

This device complies with RSS-210 of the Industry Canada Rules. Operation is subject to the following two conditions: (1) This device may not cause harmful interference, and (2) this device must accept any interference received, including interference that may cause undesired operation.

French:

Ce dispositif est conforme à la norme CNR-210 d'Industrie Canada applicable aux appareils radio exempts de licence. Son fonctionnement est sujet aux deux conditions suivantes: (1) le dispositif ne doit pas produire de brouillage préjudiciable, et (2) ce dispositif doit accepter tout brouillage reçu, y compris un brouillage susceptible de provoquer un fonctionnement indésirable.



The Safety Company

1000 Cranberry Woods Drive
Cranberry Township, PA 16066
USA
Phone 1-800-MSA-2222
Fax 1-800-967-0398

For your local MSA contacts, please go to our website www.MSAafety.com

Contents

1	Instrument Safety	4
2	Using the ALTAIR Single Gas Detector	5
2.1	Changing Alarm Setpoints	6
2.2	Activating the ALTAIR Single Gas Detector	8
2.3	ALTAIR Alarms	11
2.4	Oxygen Measurements	11
2.5	Accessing the Instrument Pages	12
2.6	Event Logging	14
3	ALTAIR Function Checks	15
4	Calibrating the ALTAIR Single Gas Detector	17
4.1	Calibrating the Toxic Gas Instruments (CO and H ₂ S)	17
4.2	Calibrating an Oxygen Instrument	21
5	Warranty, Maintenance, and Troubleshooting	23
5.1	MSA Portable Instrument Warranty	23
5.2	Troubleshooting	23
6	Specifications	26
6.1	Instrument Specifications	26
6.2	Event Logging Specifications	26
7	Replacement and Accessory Parts	27

1 Instrument Safety

The ALTAIR Single Gas Detector is:

- For use by trained, qualified personnel
- For use as a warning device only and not for measuring specific gas concentrations
- To be used when performing a hazard assessment to:
 - Assess potential worker exposure to specific toxic gases for which a sensor is installed
 - Oxygen-deficient or oxygen-rich atmospheres

NOTE: Although the ALTAIR unit will detect up to 25% oxygen, all ALTAIR versions are not certified or classified for use in atmospheres containing more than 21.0% oxygen.

WARNING!

- Read and follow all instructions carefully.
- Do not use this detector to sample the instrument's specified gas in gases other than air.
- Do not use the device to test for toxic gases in the following atmospheres as this may result in erroneous readings:
 - Reducing atmospheres
 - Furnace stacks
 - Inert environments
 - Atmospheres containing combustible airborne mists/dusts.
- Do not use the device to test for toxic gases in oxygen-deficient (<19.5 % vol) or oxygen-rich (>20.8 % vol) atmospheres, as this may result in erroneous readings.
- Perform an alarm test and a bump test before each day's use. If the instrument fails either check, the instrument must be taken out of service.
- Do not use the instrument if it is damaged.
- Calibrate the instrument if it is subjected to physical shock.
- The instrument is factory-sealed and contains no user serviceable parts. Do not attempt to open the instrument. Do not attempt to repair the instrument. Substitution of components may impair intrinsic safety.
- This unit contains a lithium battery; dispose of according to local regulations.
- Do not rely on the vibrating alarm in cold temperatures(<0°C) as the vibrating alarm may cease to operate under these conditions.
- Use only to detect a gas for which a sensor is installed.
- Do not block sensor.
- Do not use pressurized air to clean the sensor holes.
- All instrument readings and information must be interpreted by someone trained and qualified in interpreting instrument readings in relation to the specific environment, industrial practice and exposure limitations.

Failure to follow these warnings can result in serious personal injury or death.

2 Using the ALTAIR Single Gas Detector

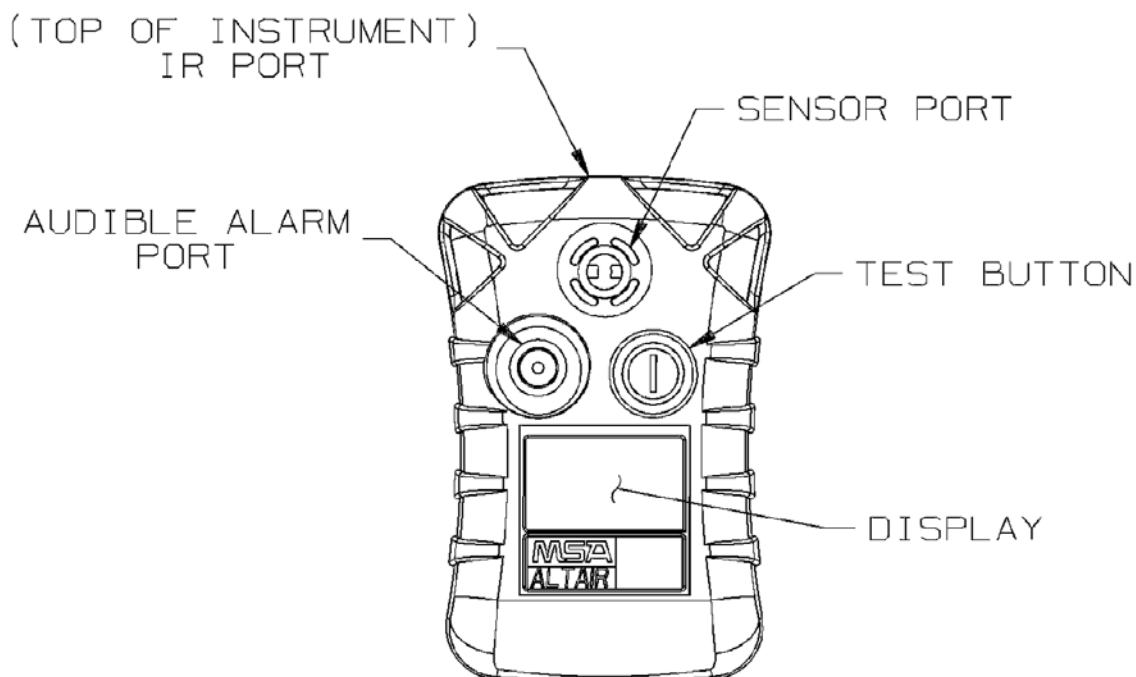

Figure 1 ALTAIR Overview

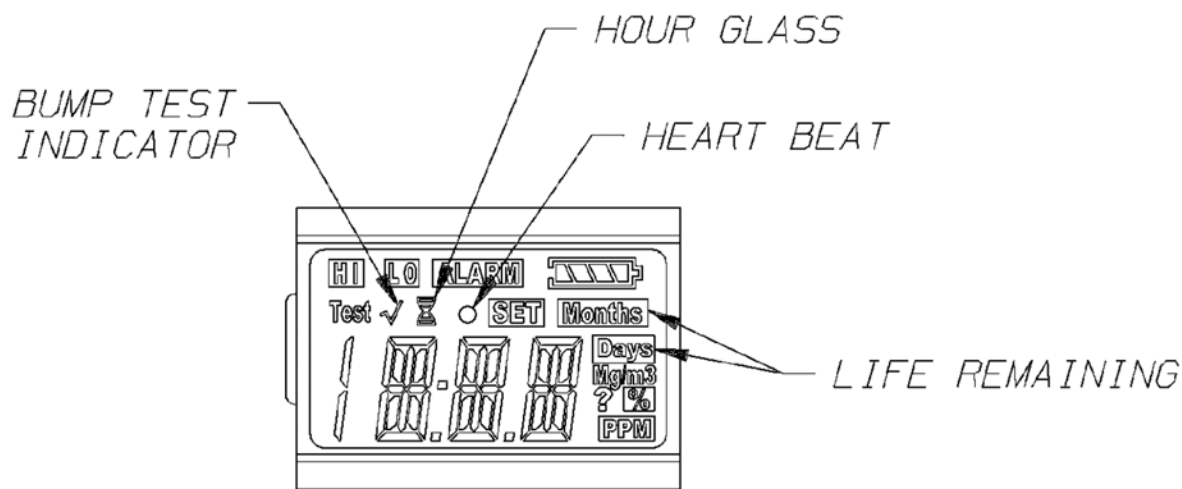

Figure 2 ALTAIR Display

2.1 Changing Alarm Setpoints

NOTE: Alarm setpoints can only be changed manually during or before activation. Once the instrument is activated, the Alarm setpoints can be changed via the MSA FiveStar® LINK™ Software with IR communications.

To change Alarm setpoints before activation:

1. Press the "TEST" button once.
 - "TEST" displays.
 - After approximately one second, all segments and the LED activate.
 - The horn, LEDs, and vibrator also activate
 - The Software Version displays for three seconds ("CO", "H₂S", or "O₂").
2. Alarm Setpoints display the:
 - **Low Alarm Setpoint** for three seconds
 - LO and ALARM icons turn ON
 - a. To change the low alarm setpoint, press the TEST button when "LO" "ALARM" displays:
 - "LO" "ALARM" "SET" "?" displays.
 - b. Press and hold the TEST button to increment the low alarm value.
 - c. Once the correct value displays, release the TEST button and wait three seconds to continue.
 - **High Alarm Setpoint** for three seconds
 - HI and ALARM icons turn ON
 - a. To change the high alarm setpoint, press the TEST button when "HI" "ALARM" displays:
 - "HI" "ALARM" "SET" "?" displays
 - b. Press and hold the TEST button to increment the high alarm value.
 - c. Once the correct value displays, release the TEST button and wait three seconds to continue.
3. Wait three seconds.
 - the unit again turns OFF.

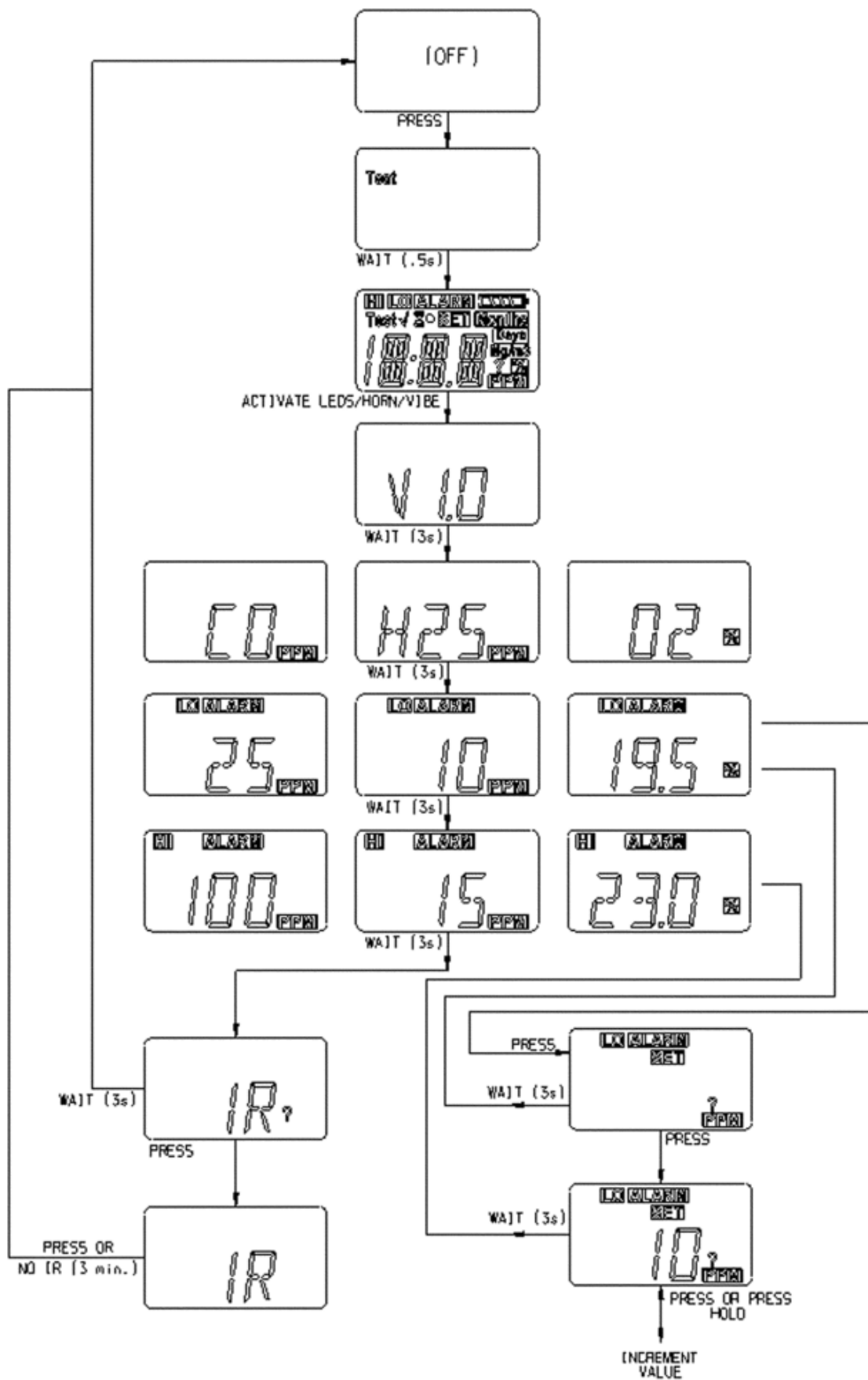

Figure 3 Changing the Alarm Setpoints

2.2 Activating the ALTAIR Single Gas Detector

WARNING!

Do not use the instrument for gas detection prior to activating the instrument.

Failure to follow this warning can result in serious personal injury or death.

1. The unit must be activated before it can be used to warn the user of a potentially hazardous condition.
 - a. To activate the personal protection instrument, press and hold the TEST button for three seconds until "ON" and "?" are displayed.
 - b. Release the button and press once again to activate.
2. The following occurs:
 - an LCD Functional Test activates the cell segments
 - the horn, LEDs and vibrator also activate.
3. The Software Version displays for three seconds.
4. The instrument gas type displays for three seconds ("CO", "H₂S", or "O₂").
5. Alarm Setpoints display the:
 - **Low Alarm Setpoint** for three seconds
 - "LO" and "ALARM" icons turn ON
 - a. To change the low alarm setpoint, press the TEST button when "LO" "ALARM" display:
 - "LO" "ALARM" "SET" "?" displays.
 - b. Press and hold the TEST button to increment the low alarm value:
 - Once the maximum setpoint allowed is reached, this value rolls over and begins again at the lowest value.
 - c. Once the correct value displays, release the TEST button and wait three seconds to continue.
 - **High Alarm Setpoint** for three seconds
 - "HI" and "ALARM" icons turn ON
 - a. To change the high alarm setpoint, press the TEST button when "HI" "ALARM" displays:
 - "HI" "ALARM" "SET" "?" displays.
 - b. Press and hold the TEST button to increment the high alarm value.
 - Once the maximum setpoint allowed is reached, this value rolls over and begins again at the lowest value.
 - c. Once the correct value displays, release the TEST button and wait three seconds to continue.
6. The instrument now performs a 99-second activation countdown.
 - Once activated, the instrument remains active until a Low Battery error occurs.
 - The Months Remaining counter begins at 24 months and counts down.

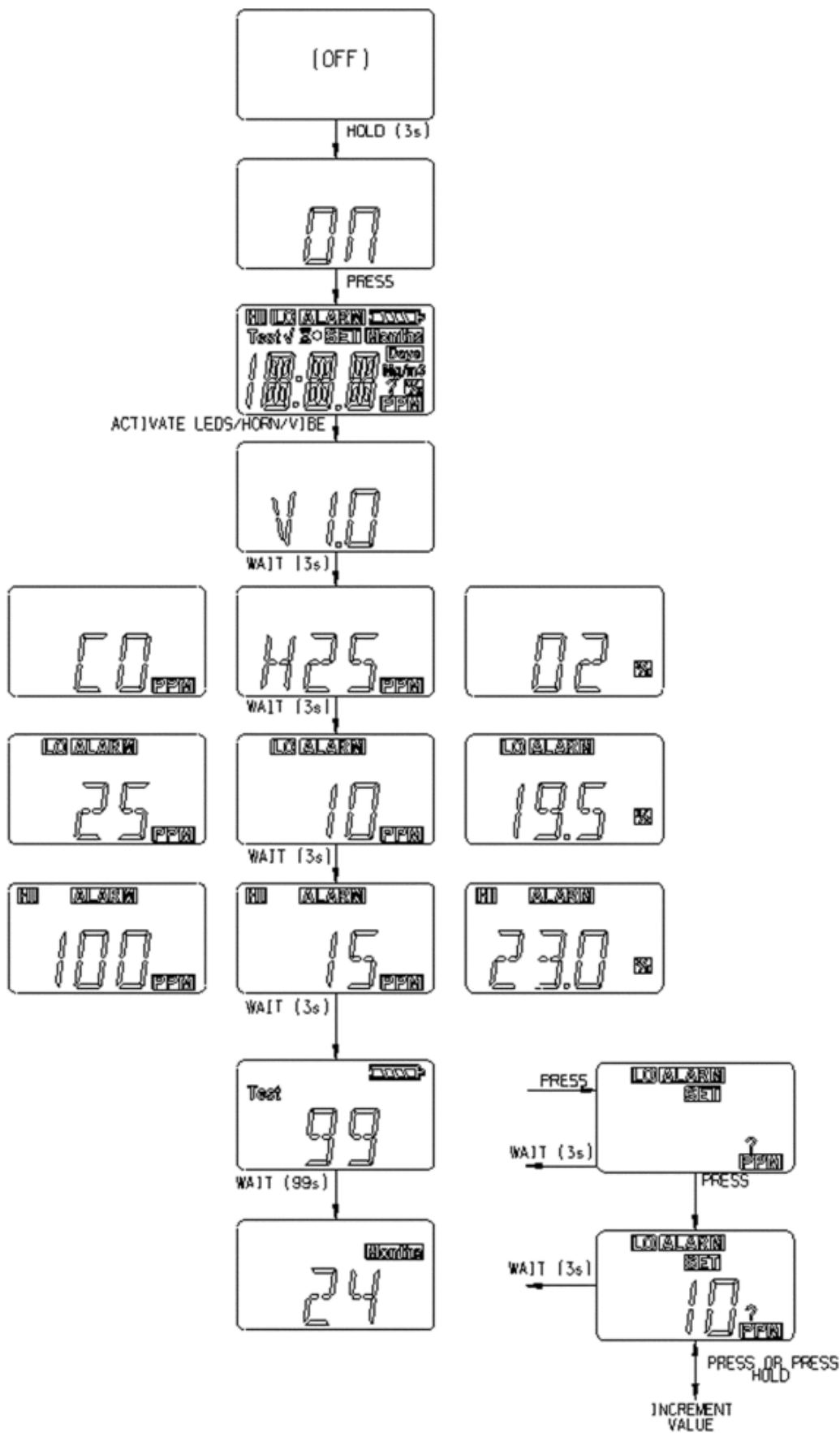

Figure 4 ALTAIR Activation Flow Chart

Time Remaining (check before each day's use)

- In normal operating mode, the ALTAIR Detector's remaining operating time (0 to 24 months) is always displayed.
- When less than one month remains, the display changes to the number of *days* remaining.
- The instrument is designed to continue to operate after 24 months have elapsed. A "+" followed by a numerical value and "months" or "days" indicates that more than 24 months have expired.
- For the instrument to function properly (including after the 24-month initial period has elapsed), the end user must continue to perform an alarm function check and bump test before each day's use.
- The instrument will continue to operate as long as:
 - The Low Battery warning indicator is not displayed.
 - The instrument continues to pass the bump test as outlined in this manual.
- For the oxygen version:
 - If, after the initial 24-month period, the sensor output is less than 5% O₂ for more than five minutes, then it is considered a sensor failure:
 - Instrument will display "SNS/ERR".
- If the battery reaches its end of life, the
 - **Low Battery warning** indicator activates:
 - User must discontinue using the ALTAIR Single Gas Detector at this time, although the instrument is still detecting gas.
 - Low Battery indicator flashes.
 - Months remaining continues to display.

WARNING!

If Low Battery warning activates while using the device, leave the area immediately and remove the instrument from service. The end of battery life is approaching.

Failure to follow this warning can result in serious personal injury or death.

- **Low Battery alarm** activates:
 - Horn sounds
 - LEDs flash
 - Low Battery indicator flashes
 - "ERR" displays
 - Pressing the "TEST" button silences the alarm
 - Unit is no longer detecting gas and must be taken out of service.

WARNING!

If a Low Battery alarm activates, leave the area immediately and remove the instrument from service. The device no longer has enough power to indicate potential hazards.

Failure to follow this warning can result in serious personal injury or death.

Confidence Indicator (see [Figure 2](#))

The Confidence Indicator flashes once every 60 seconds to notify the user that the instrument is ON and operating normally. In addition, both LEDs will flash briefly every 60 seconds.

2.3 ALTAIR Alarms

Toxic Gas Measurements (see Figure 1)

The ALTAIR Detector can be purchased to detect the following gases in the atmosphere:

- Carbon Monoxide (CO) or
- Hydrogen Sulfide (H₂S).

There are two alarm setpoints in the instrument.

1. If the gas concentration reaches or exceeds the low alarm setpoint:
 - The instrument will:
 - display and flash "LO" and "ALARM" on the LCD
 - enter a low alarm sequence.
 - The low alarm can be silenced for five seconds by pressing the TEST button; it automatically clears once the gas level falls below the setpoint.
 2. If the gas concentration reaches or exceeds the high alarm setpoint:
 - The instrument will:
 - display and flash "HI" and "ALARM" on the LCD
 - enter a High alarm sequence
 - The high alarm can be silenced for five seconds by pressing the TEST button; it automatically clears once the gas level falls below the setpoint.
- Refer to the instrument during Test mode for factory-set alarm setpoints.
 - If a gas concentration exceeds an alarm setpoint, the:
 - Audible alarm sounds
 - Alarm lights flash
 - Vibrator activates
 - Alarm type displays, alternately flashing the ALARM icon and the:
 - LO icon (if the low alarm setpoint was exceeded)
 - HI icon (if the high alarm setpoint was exceeded)

WARNING!

If a toxic or oxygen gas alarm condition is reached while using the instrument as a personal or area monitor, leave the area immediately; the ambient condition has reached a preset alarm level.

Failure to follow this warning can result in serious personal injury or death.

2.4 Oxygen Measurements

The ALTAIR Detector can be purchased to measure the concentration of oxygen in an atmosphere. High and Low alarm setpoints can be configured to alarm in any combination of oxygen:

- enrichment (greater than 20.8%) or
- depletion (less than 20.8%).

When an alarm setpoint is reached, the:

- Audible alarm sounds
- Alarm light flash
- Vibrator activates

- Type of alarm displays by alternately flashing the ALARM icon and the LO or HIGH icon, depending on how the Low and High alarms were set.
- Low Alarm indicates:
 - the lower %O₂ level of the two alarm settings
 - a more urgent condition and the faster alarm sequence will be indicated
 - "LO" "ALARM" displays.

NOTE: False oxygen alarms can occur due to barometric pressure (altitude) changes or extreme changes in ambient temperature. It is recommended that an oxygen calibration be performed at the temperature and pressure of use. Be sure that the instrument is in known fresh air before performing a calibration.

2.5 Accessing the Instrument Pages

The Information page can be accessed by pushing the TEST button once. This information includes:

1. Current oxygen reading in %O₂ (oxygen versions only)
2. Test gas mode
3. Functional check of LCD, vibrator, LEDs and horn
4. Gas type
5. Low Alarm setpoint ("LO" "Alarm")
6. High Alarm setpoint ("HI" "Alarm")
7. Minimum Oxygen concentration ("LO") - for oxygen only
8. Peak Reading
 - Toxic ("HI")
 - Oxygen ("HI")
 - The Peak/ Hi and Min/ Low values can be cleared.
 - When this page is displayed, press the TEST button to clear.
 - "CLR" displays.
9. Alarm Time in hours (hour glass "HRS" and number of hours)
10. IR mode.
 - When instrument displays "IF?", press button to enter IR mode.
 - If IR communications are not detected for three minutes or the TEST button is pressed, the instrument will exit this mode.
 - See [Figure 5](#) for additional details.

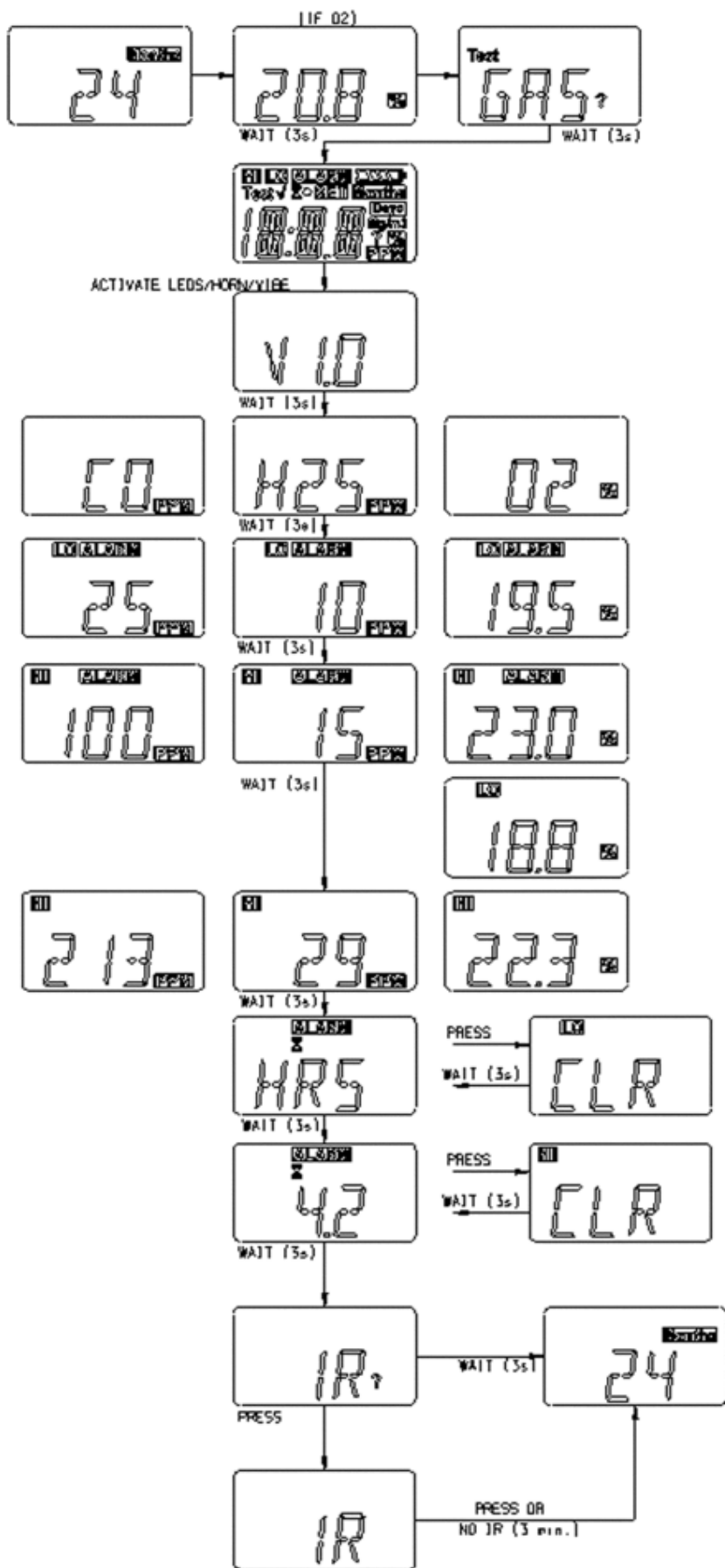

Figure 5 Accessing ALTAIR Pages Flow Chart

2.6 Event Logging

- The ALTAIR Single Gas instrument has the capability of recording 25 of the most recent events.

Press the TEST button.

- The instrument pages begin to display
- Events will be transferred to the PC during this sequence, if:
 - the top of the instrument is pointed toward the optional IR Receiving device
 - a PC is running MSA FiveStar Link Software (P/N 710946)
 - "CONNECT" is pressed in the PC FiveStar LINK Software package.
- The following events are recorded:
 - Alarm - Alarm Type - Alarm Value - Time/Date
 - Alarm Clear - Alarm Type - Alarm Value - Time/Date
 - Cal (Pass/Fail) - Time/ Date
 - Bump (Pass/Fail) - Time/ Date
 - Error Non-Shutdown - Error Type (See Error List) - Time/Date
 - End of Life - Reason (Error - see Error List) - Time/Date

NOTE: The time and date is based on the PC time and date. Ensure the PC is correct before the events are transferred.

NOTE: Instrument power loss can result in lost time in the session log.

3 ALTAIR Function Checks

Confidence and Heartbeat Indicator

- The alarm lights and heartbeat indicator on the display will flash approximately every 60 seconds to indicate that the ALTAIR Detector is operating.

WARNING!

Perform an alarm test and a bump test before each day's use. If the instrument fails either check, the instrument must be taken out of service.

Failure to follow this warning can result in serious personal injury or death.

Alarm Test

- Check before each day's use.
- Press the TEST button momentarily. A one-second test of the alarms will occur; this includes the:
 - display
 - alarm lights
 - vibrator
 - horn.
- If these items do not activate, remove the instrument from service.

Bump Test

- Check before each day's use.
- Press the TEST button momentarily:
 - oxygen versions will display the current oxygen reading; calibrate the unit if it reads other than 20.8%.
 - "TEST" "GAS" "?" will display.
 - alarm test will activate.
- Press the TEST button again while "TEST" "GAS" "?" is displayed to activate the Bump Test mode.
 - the hourglass and "GAS" will display.
- Apply gas only **AFTER** the hourglass and "GAS" are displayed.
 - If gas is detected, the display will indicate "OK".

NOTE: See [Table 1](#) for applied gases.

- Press the TEST button again:
 - The "√" that appears on the display:
 - indicates that the instrument passed the bump test.
 - remains for 24 hours, indicating that a bump test was performed on this instrument within that last 24 hours.

NOTE: See [Figure 6](#) for details.

- If the "√" does not appear and "ERR" is indicated:
 - Check that the:
 - Sensor inlet is not clogged
 - correct calibration cylinder is used to perform the bump test
 - gas cylinder has not expired and is not empty
 - gas was applied at the appropriate time
 - gas tubing is seated in the front instrument case during testing.

3 ALTAIR Function Checks

- Repeat the bump test process as needed.
- If the "√" does not appear, calibrate the instrument and repeat the Bump Test.

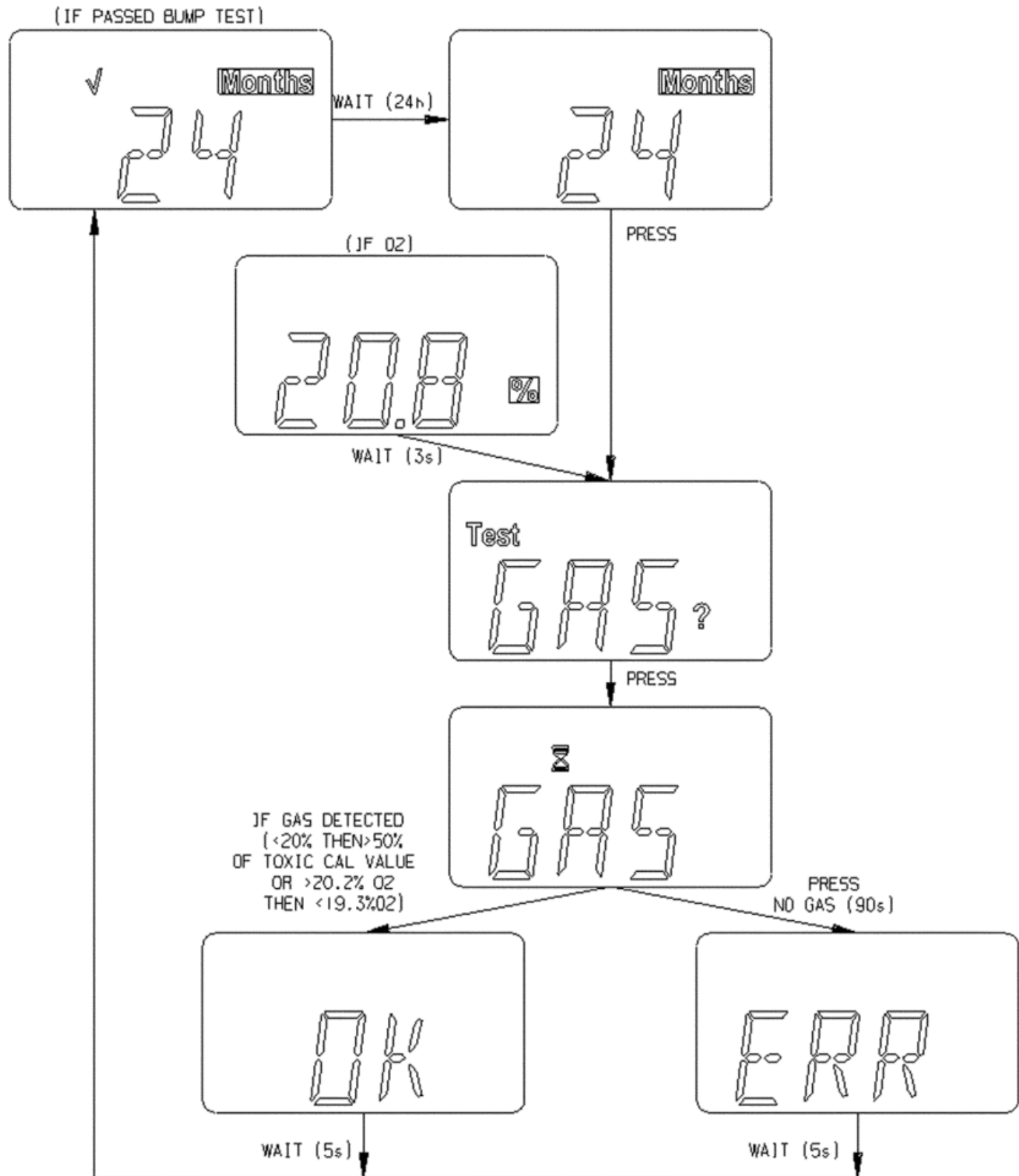

Figure 6 Bump Test Flow Chart

Table 1 Calibration/Bump Test Values

INSTRUMENT TYPE	BUMP TEST GAS	CALIBRATION GAS
CO	60 ppm	60ppm
H ₂ S	40 ppm	40 ppm
O ₂	<19%*	20.8%

*The O₂ bump test can also be performed by exhaling on the sensor inlet for approximately three to five seconds.

4 Calibrating the ALTAIR Single Gas Detector

WARNING!

Perform a calibration per the instructions in this user guide. Do not continue operation of a detector that is not able to pass calibration.

Failure to follow this warning can result in serious personal injury or death.

- While the ALTAIR Single Gas detector is designed to be a maintenance free instrument, under normal circumstances MSA recommends calibration at least every six months or in accordance with local regulations. The device must be calibrated if it does not pass a Bump Test or if any of the conditions listed below exist.
- For oxygen instruments, perform a calibration if any of the following occur:
 - physical shock
 - there are changes in barometric pressure (altitude changes)
 - there are extreme changes in ambient temperature and humidity (see [6.1 Instrument Specifications](#)).
 - the instrument does not pass a bump test.
- For toxic instruments (CO and H₂S), perform a calibration if any of the following occur:
 - physical shock
 - extended use in extreme temperatures
 - high concentration exposure
 - the instrument does not pass a bump test.

4.1 Calibrating the Toxic Gas Instruments (CO and H₂S)

To enter the calibration mode, make sure you are in fresh, uncontaminated air. See [Figure 7](#) for more details.

WARNING!

Do not perform calibration unless you are certain you are in fresh, uncontaminated air; otherwise, inaccurate readings can occur which can falsely indicate that a hazardous atmosphere is safe.

Failure to follow this warning can result in serious personal injury or death.

1. In normal operating mode, press the TEST button.
 - "TEST" "GAS" "?" displays.
2. Press and hold the TEST button for three seconds when the "TEST" "GAS" "?" displays.
 - "TEST" "CAL" screen displays
 - After three seconds, "FAS" "?" displays asking the user if a fresh air setup/calibration is desired.
3. Press the TEST button to enter zero calibration.

NOTE: Otherwise, the instrument will return to the normal operating mode.

4. During zero calibration:

4 Calibrating the ALTAIR Single Gas Detector

- the hour glass and "FAS" display
 - If the instrument successfully calibrates:
 - "OK" displays
 - If the instrument does not successfully calibrate:
 - "ERR" displays
 - instrument returns to normal operating mode after five seconds.
5. Once the instrument successfully calibrates and the "OK" displays, press the TEST button to enter calibration.
- "CAL" "?" displays.
6. While the "CAL" "?" displays, press the TEST button to enter the Gas Calibration mode.
- The current expected test gas is shown (in ppm).
- a. To change the expected calibration gas:
- 1) Press the TEST button
 - "TEST" "SET" "?" "ppm" displays.
 - 2) Press the TEST button again to set (hold the TEST button to scroll to a different value).
 - 3) Wait three seconds to return to the Calibration mode.

WARNING!

The expected gas concentrations must match the gas concentrations listed on the calibrations cylinder(s).

Failure to follow this warning will cause an incorrect calibration, which can result in serious personal injury or death.

- b. Apply the appropriate test gas
 - The display toggles between the current gas reading, the hourglass and "CAL".
 - Once the instrument passes calibration (this will take no more than 90 seconds), "OK" displays.
 - Otherwise, "ERR" displays.
 - Wait five seconds to return to the normal operating mode.
- c. If "ERR" displays after calibration, the current settings did not change. Immediately check that:
 - The calibration cylinder matches the expected calibration value expected in the instrument
 - The calibration cylinder is not empty and has not expired.
 - The regulator is 0.25 liters/ minute
 - The tubing is seated in the front instrument case during gas calibration mode.
 - If necessary, repeat steps 1 through 6.
 - The display must read "OK"; if "ERR" remains, remove the instrument from service.
- d. Perform a bump test to confirm operation and activate the "√".

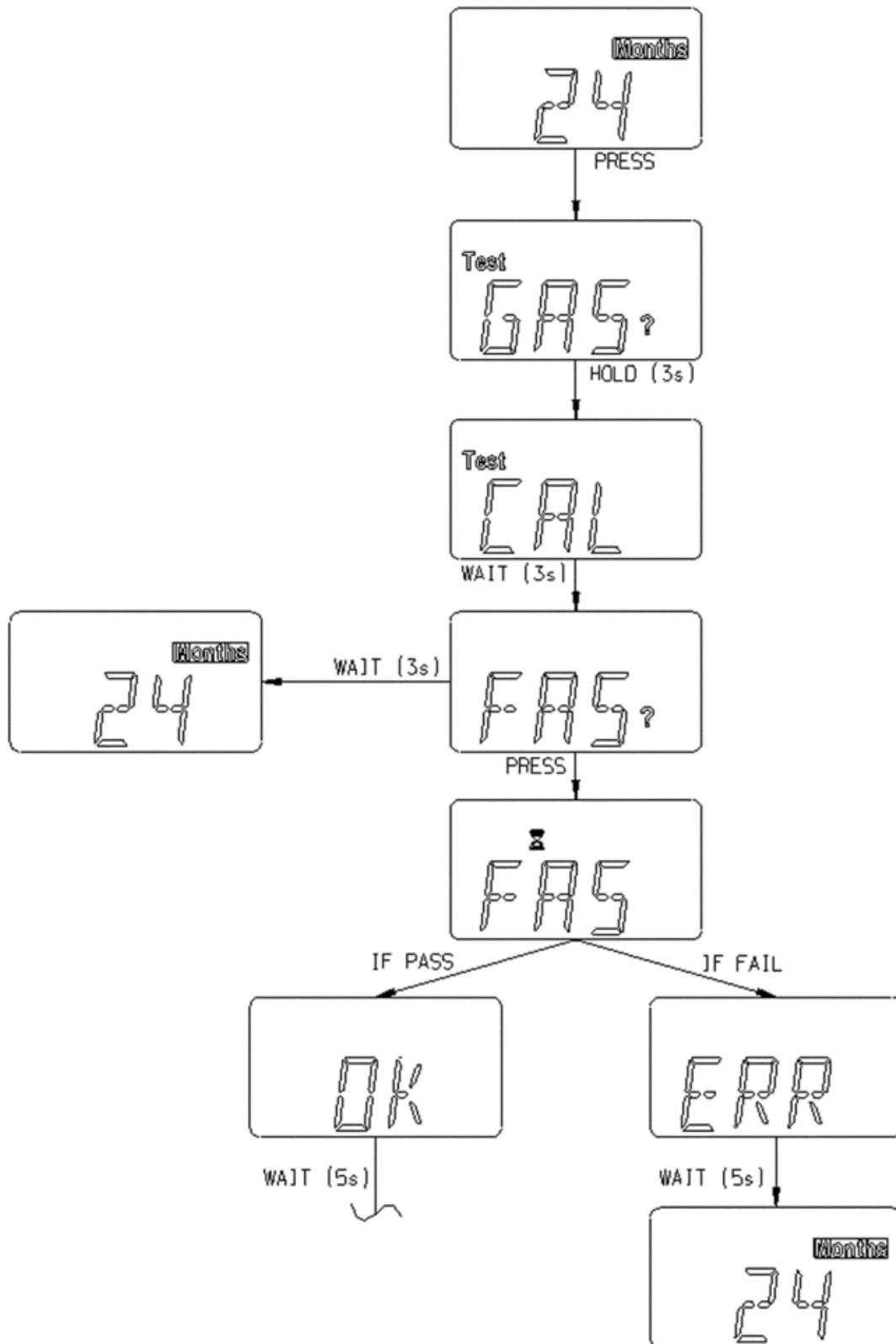

Figure 7 Calibration (Toxics) Flow Chart (part 1 of 2)

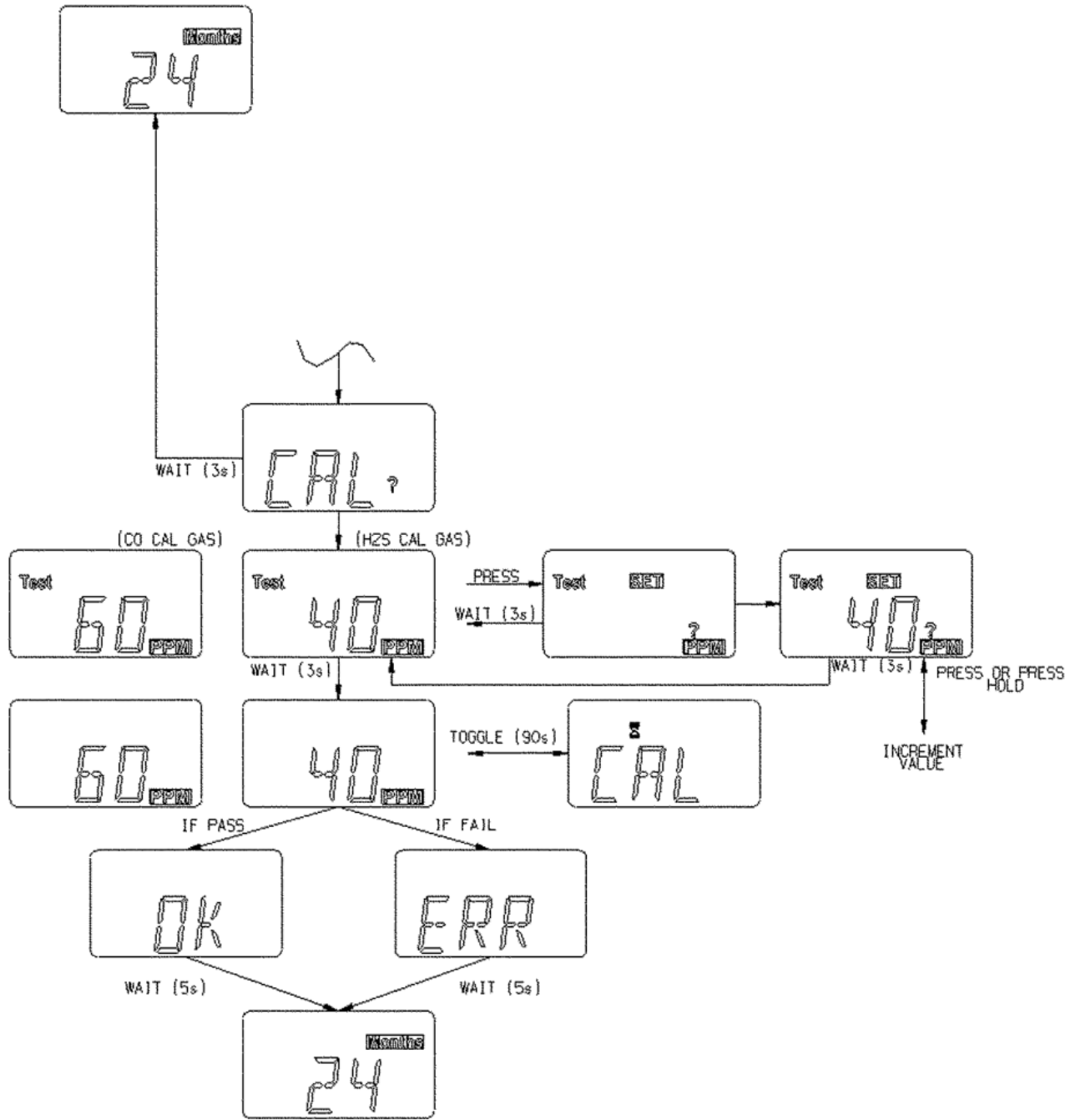

Figure 8 Calibration (Toxics) Flow Chart (part 2 of 2)

4.2 Calibrating an Oxygen Instrument

- False oxygen alarms can occur due to changes in barometric pressure (altitude changes) or extreme changes in ambient temperature.
- The ALTAIR Detector is equipped with a feature to allow calibration at pressure and/ or temperature of use.
- Be sure that the instrument is in known fresh air before performing a calibration.
- The ALTAIR Oxygen instrument has the ability to display the current Oxygen level with a press of the TEST button. See "[Using the ALTAIR Single Gas Detector](#)" for more details. If this reading is other than 20.8%, a calibration is required in air that is known to be safe.

To enter the calibration mode, make sure you are in fresh, uncontaminated air.

WARNING!

Do not perform calibration unless you are certain you are in fresh, uncontaminated air; otherwise, inaccurate readings can occur which can falsely indicate that a hazardous atmosphere is safe.

Failure to follow this warning can result in serious personal injury or death.

1. In normal operating mode, press the TEST button.
 - The current Oxygen reading displays.
 - See [Figure 9](#) for more details.
2. When the "TEST" "GAS" "?" displays, press and hold the TEST button to enter calibration.
 - "TEST" "CAL" displays
 - After three seconds, "FAS" "?" displays asking the user if a fresh air setup/ calibration is desired.
3. Press the TEST button at the "FAS" "?" screen to perform a calibration at 20.8% O₂.

NOTE: This procedure must be performed in fresh, uncontaminated air. Do not breathe on the sensor while performing this function.

- If the sensor successfully calibrates:
 - "OK" displays
 - If the sensor does not successfully calibrate:
 - "ERR" displays.
4. Wait five seconds.
 - The instrument returns to normal operating mode.
 5. If "ERR" displays after calibration, the current settings did not change. Immediately check that:
 - The instrument is in fresh, uncontaminated air during the calibration process.
 - No one breathes on the sensor during calibration.
 - Repeat steps 1 through 6, as necessary.
 6. The display must read "OK"; if "ERR" remains, remove the instrument from service.
 7. Perform a bump test to confirm operation and activate the "√".

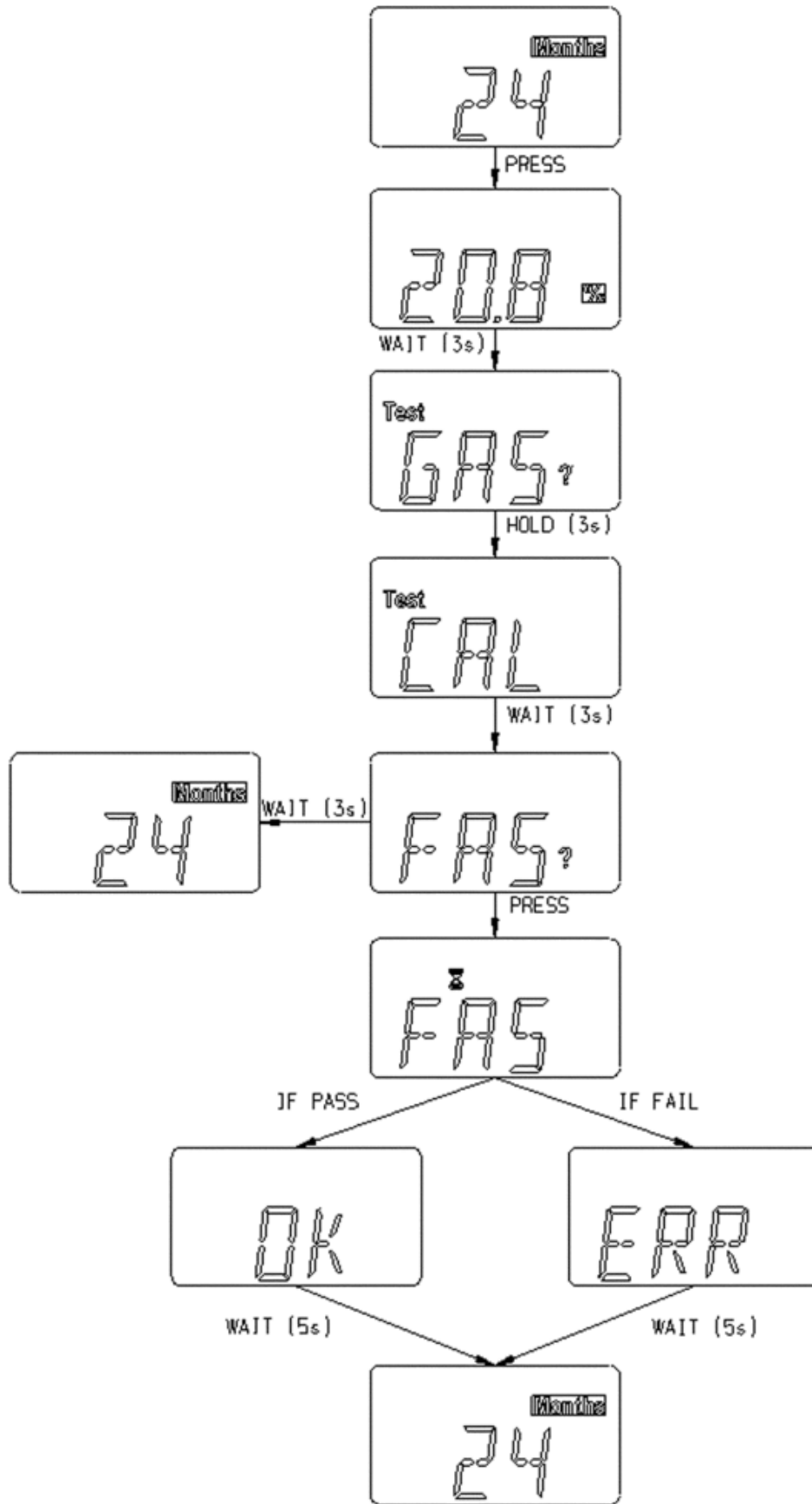

Figure 9 Calibration (Oxygen) Flow Chart

5 Warranty, Maintenance, and Troubleshooting

5.1 MSA Portable Instrument Warranty

1. Warranty - MSA warrants that this product will be free from mechanical defects and faulty workmanship for a period of two (2) years from date of activation (given six months storage maximum before actuation from the date of manufacture or 18 hours total alarm time, whichever is first), provided it is maintained and used in accordance with MSA's instructions and/or recommendations. MSA shall be released from all obligations under this warranty in the event repairs or modifications are made by persons other than its own authorized service personnel or if the warranty claim results from accident, alteration, physical abuse, or misuse of the product. Normal wear and tear is also excluded. No agent, employee or representative of MSA may bind MSA to any affirmation, representation or modification of the warranty concerning the goods sold under this contract. MSA makes no warranty concerning components or accessories not manufactured by MSA, but will pass on to the Purchaser all warranties of manufacturers of such components. **THIS WARRANTY IS IN LIEU OF ALL OTHER WARRANTIES, EXPRESS, IMPLIED OR STATUTORY, AND IS STRICTLY LIMITED TO THE TERMS HEREOF. SELLER SPECIFICALLY DISCLAIMS ANY WARRANTY OF MERCHANTABILITY OR FITNESS FOR A PARTICULAR PURPOSE.**
2. **Exclusive Remedy** – It is expressly agreed that the Purchaser's sole and exclusive remedy for breach of the above warranty, or for any other cause of action (including tortious conduct) arising out of or related to the same, shall be the repair and/or replacement, at MSA's option, of any equipment or parts thereof, that after examination by MSA are proven to be defective. Replacement equipment and/or parts will be provided at no cost to the Purchaser, F.O.B. Purchaser's named place of destination. **FAILURE OF MSA TO SUCCESSFULLY REPAIR ANY NONCONFORMING PRODUCT SHALL NOT CAUSE THE REMEDY ESTABLISHED HEREBY TO FAIL OF ITS ESSENTIAL PURPOSE.**
3. **Exclusion of Consequential Damages** – **PURCHASER SPECIFICALLY UNDERSTANDS AND AGREES THAT UNDER NO CIRCUMSTANCES WILL MSA BE LIABLE TO PURCHASER FOR ECONOMIC, SPECIAL, INCIDENTAL, OR CONSEQUENTIAL DAMAGES OR LOSSES OF ANY KIND WHATSOEVER, INCLUDING BUT NOT LIMITED TO, LOSS OF ANTICIPATED PROFITS AND ANY OTHER LOSS CAUSED BY REASON OF THE NON-OPERATION OF THE GOODS.** This exclusion is applicable to claims for breach of warranty, tortious conduct or any other cause of action against MSA.
4. Warranty - MSA warrants that this product will be free from mechanical defects and faulty workmanship for a period of two (2) years from date of activation (given six months storage maximum before actuation from the date of manufacture or 18 hours total alarm time, whichever is first), provided it is maintained and used in accordance with MSA's instructions and/ or recommendations. MSA shall be released from all obligations under this warranty in the even repairs or modifications are made by persons other than its own or authorized service personnel or if the warranty claim results from physical abuse or misuse of the product. No agent, employee or representative of MSA has any authority to bind MSA to any affirmation, representation or warranty concerning the goods sold under this contract. **THIS WARRANTY IS IN LIEU OF ALL OTHER WARRANTIES, EXPRESSED, IMPLIED OR STATUTORY, AND IS STRICTLY LIMITED TO THE TERMS HEREOF. SELLER SPECIFICALLY DISCLAIMS ANY WARRANTY OF MERCHANTABILITY OR OF FITNESS FOR A PARTICULAR PURPOSE.**
5. **Exclusive Remedy** - It is expressly agreed that Purchaser's sole and exclusive remedy for breach of the above warranty, for any tortious conduct of MSA, or for any other cause of action, shall be the repair and/ or replacement at MSA's option, of any equipment or parts thereof, which after examination by MSA is proven to be defective. Replacement equipment and/ or parts will be provided at no cost to Purchaser, F.O.B. MSA's Plant. Failure of MSA to successfully repair any nonconforming product shall not cause the remedy established hereby to fail of its essential purpose.
6. **Exclusion of Consequential Damage** - Purchases specifically understands and agrees that under no circumstances will MSA be liable to Purchaser for economic, special, incidental or consequential damages or losses of any kind whatsoever, including but not limited to, loss of anticipated profits and any other loss caused by reason of non-operation of the goods. This exclusion is applicable to claims for breach of warranty, tortious conduct or any other cause of action against MSA.

5.2 Troubleshooting

The ALTAIR Single Gas Detector will operate reliably when handled properly. If the instrument becomes inoperative, follow the Troubleshooting Guidelines in [Table 2](#) ; these represent the most likely causes of a problem. You may return

inoperative instruments that are under warranty to MSA:

MSA North America Repair and Service Department
1000 Cranberry Woods Drive
Cranberry Township, PA 16066-5207
1-800-MSA-INST

To contact MSA International, please call:
1-412-967-3000 or 1-800-MSA-7777

WARNING!

Repair or alteration of the ALTAIR Single Gas Detector, beyond the procedures described in this manual or by anyone other than a person authorized by MSA, could cause the instrument to fail to perform properly. Use only genuine MSA replacement parts when performing any maintenance procedures described in this manual. Substitution of components can seriously impair instrument performance, alter intrinsic safety characteristics or void agency approvals.

Failure to follow this warning can result in serious personal injury or death.

The instrument displays an error code if it detects a problem during startup or operation. See [Table 2](#) for a brief description of the error and proper corrective action.

Table 2 Troubleshooting Guidelines

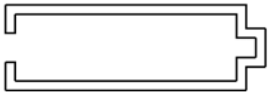
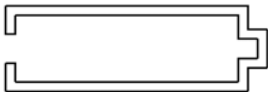
Problem	Description	Action
Display Toggles Between:		
TMP/ ERR	Temperature out of range	Remove from service. Contact MSA during warranty period.
AD/ ERR	Sensor feedback error	Remove from service. Contact MSA during warranty period.
EE/ ERR	EEPROM inoperative	Remove from service. Contact MSA during warranty period.
MEM/ RST	EEPROM Data Error	Calibrate instrument. Reconfigure any custom settings (alarm setpoints, datalog, etc.) Remove from service. Contact MSA during warranty period.
PRG/ ERR	Program Memory inoperative	Remove from service. Contact MSA during warranty period.
RAM/ ERR	RAM inoperative	Remove from service. Contact MSA during warranty period.
TMR/ ERR	Time or Clock Error	Remove from service. Contact MSA during warranty period.
BTN/ ERR PWR/ ERR	Button error (stuck down) Unexpected Power Loss Error	Remove from service. Contact MSA during warranty period. Remove from service. Contact MSA during warranty period.
LED/ ERR	LED inoperative	Remove from service. Contact MSA during warranty period.
VIB/ ERR alarm	Vibrator inoperative	Remove from service. Contact MSA during warranty period.
UNK/ ERR	Unknown Error	Remove from service. Contact MSA during warranty period.
UND/ ERR	Sensor under range	Calibrate instrument. If calibration does not correct this error, remove from service.
	Low battery warning indicator (no alarm)	Remove from service. Contact MSA during warranty period.
	Low battery Alarm indicator (horn sounds, LEDs activate)	Remove from service. Contact MSA during warranty period.
/ERR		
SNS/ ERR	Sensor Error	Remove from service. Contact MSA during warranty period.

6 Specifications

6.1 Instrument Specifications

OPERATING TEMPERATURE RANGE	-20 to 50°C (-4 to +122°F) Internal vibrator operates to 0°C (32°F)		
HUMIDITY	10 to 95% RH, Non condensing		
INGRESS PROTECTION	IP67		
RECOMMENDED STORAGE	0 to 40°C (32° to 104°F)		
WARRANTY	2 years after activation, maximum or 18 hours alarm time when activated within 6 months after date of manufacture		
AUDIBLE ALARM	95 dB typical		
APPROXIMATE SIZE	3.4" H x 2.0" W x 1" D (8.6 cm H x 5.1 cm W x 2.5 cm D)		
WEIGHT	4 oz (113 grams)		
SENSOR	Electrochemical Sensors		
SENSOR DETECTION RANGE	H₂S	CO	O₂
	0-100 ppm	0-500 ppm	0-25% by volume
FACTORY-SET * ALARM SETPOINTS	LOW ALARM		HIGH ALARM
	CO	25 PPM	100 PPM
	H₂S	10 PPM	15 PPM
	O₂	19.5%	23.0%
BATTERY	Lithium, non-rechargeable		

* Other setpoints available upon request. They may also be modified prior to activation through the button or at any time via MSA FiveStar Link Software.

NOTE: This instrument has not been classified for use in atmospheres containing >21% oxygen.

6.2 Event Logging Specifications

NUMBER OF SHARED EVENTS	25 (most recent occurrences)
DATA TRANSMISSION METHOD	Via MSA infrared adapter on a PC using MSA FiveStar Link Software > version 4.3
EVENT LOG INFORMATION	<ul style="list-style-type: none"> • Alarm - Alarm Type - Alarm Value - Time/Date • Alarm Clear - Alarm Type - Alarm Value - Time/Date • Cal (Pass/Fail) - Time/Date • Bump (Pass/Fail) - Time/Date • Error Non-Shutdown - Error Type (See Error List) - Time/Date • End of Life - Reason (Error - see Error List) - Alarm minutes - Months Life - Time/Date.
TRANSMISSION TIME	Typically < 60 seconds max.

7 Replacement and Accessory Parts

Replacement Parts List

PART/ COMPONENT	PART NO.
Cylinder, 60 ppm CO	710882
Cylinder, 30 ppm CO RP	473180
Cylinder, 40 ppm H ₂ S, RP	467897
Cylinder, 40 ppm H ₂ S, Econocal	711062
Regulator, 0.25 lpm	467895
Regulator, 0.25 lpm, Combination	711175
Tubing, 40 cm (16")	1003025
Clip, Suspender Style, black	10040002
Clip, Suspender Style, Stainless Steel	10069894
Cell Phone Belt Clip	10041105
Lanyard Kit	10041107
FiveStar Link with IR (optional for event logging)	710946